

PANEL MOUNT VERSION

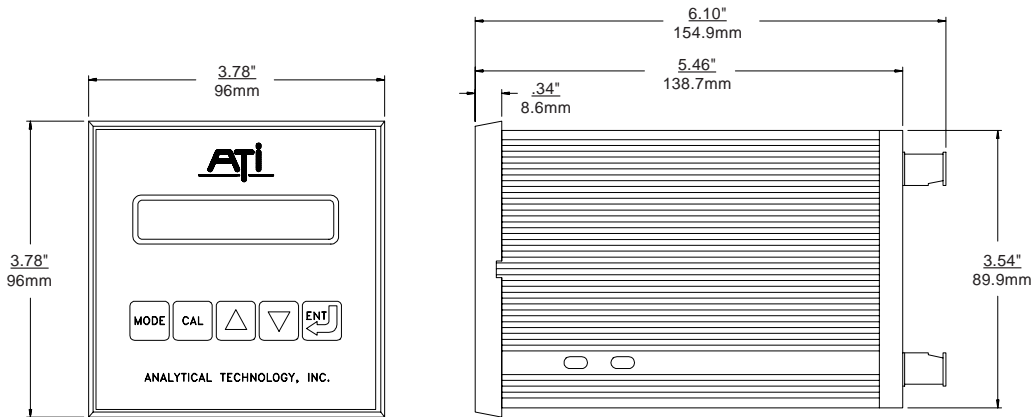

ATI-0124

NEMA-4X VERSION

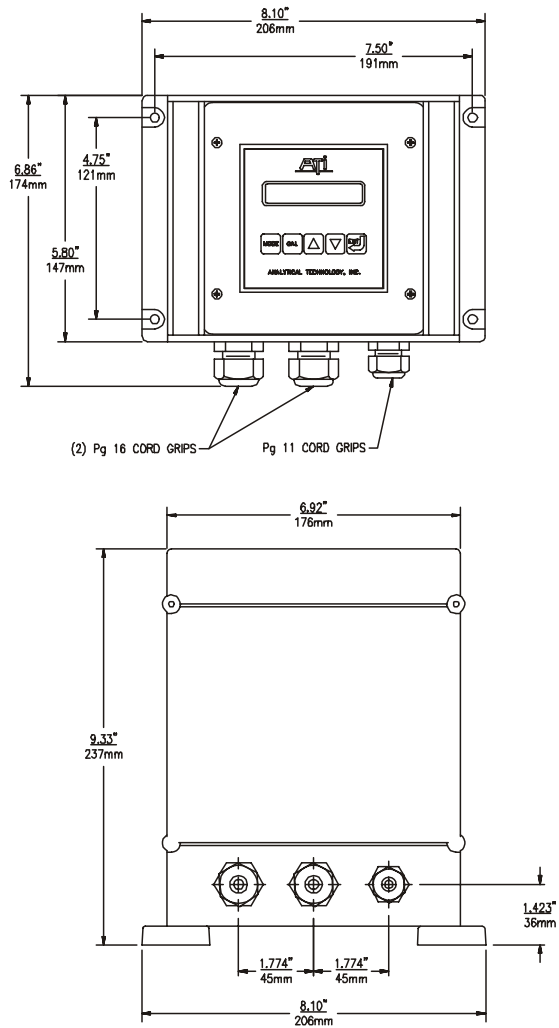

ATI-010

NOTES

- 1) Panel Mount Enclosure Material:
Aluminum, Black Anodized
- 2) Nema-4X Enclosure Material:
Base: Molded ABS, (tan in color)
Cover: Clear Polycarbonate with dual hinge.
- 3) Nema-4X Rating:

NEMA rated types 4,4X
IEC 529 rated IP66
Flammability Rating UL94 HB

JUNCTION BOX

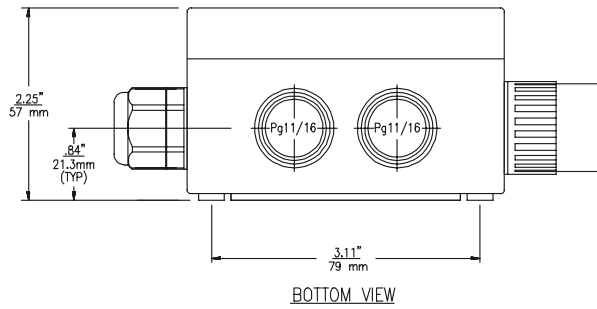
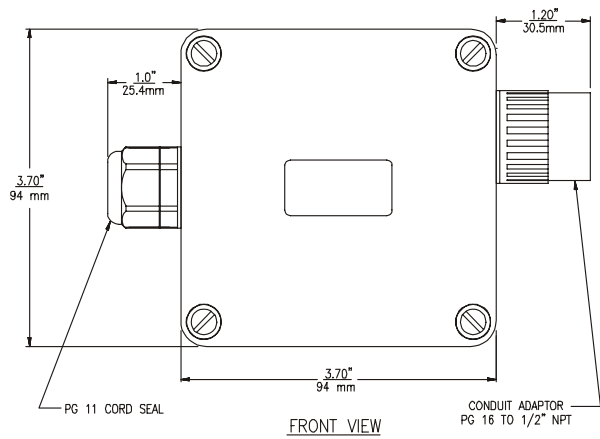

ATI-0241

NOTES

- 1) Nema-4X Enclosure Material:
Molded FRP (Fiberglass reinforced polyester), gray in color.
- 2) Nema-4X Rating:

UL listed per std. 508
CSA certified per std. C22.2 No. 94
NEMA rated types 4,4X,6,6P,12,13
CEMA rated types 2,3,4 and 5
IEC 529 rated IP 67-11
- 3) Mounting Dimensions:

3.11" [79mm] x 3.11" [79mm]
- 4) Part No. 00-0726.

PANEL MOUNT

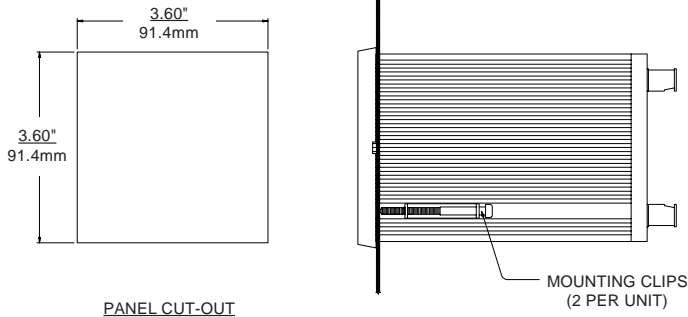

ATI-0125

WALL MOUNT - NEMA-4X

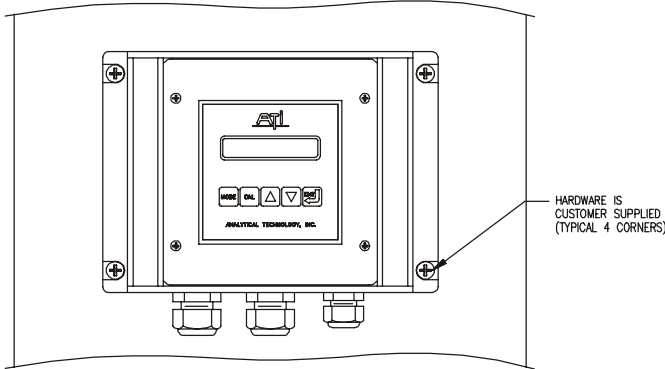

ATI-0126

HANDRAIL MOUNT - NEMA-4X

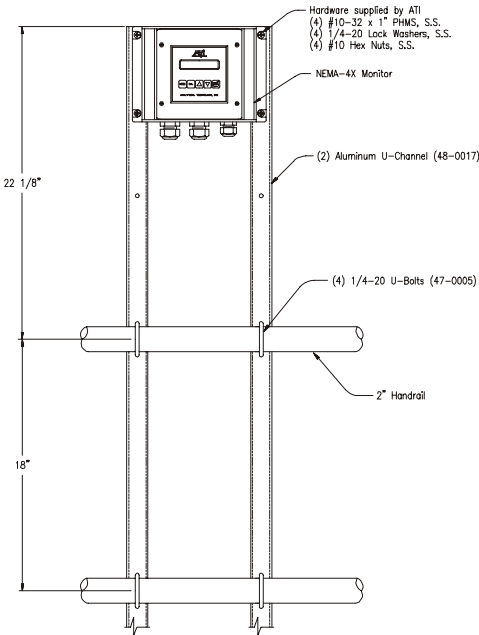

ATI-043

NOTES

- 1) Front of panel is NEMA 1, general purpose only.
- 2) Panel mounting clips supplied with monitor.

- 1) Wall mounting requires customer supplied screws or bolts.

- 1) All listed hardware is supplied as part of handrail mounting kit # 00-0139.

A15/76 TURBIDITY MONITOR ELECTRICAL CONNECTIONS

**A15/76 TURBIDITY MONITOR
(BACK VIEW)**

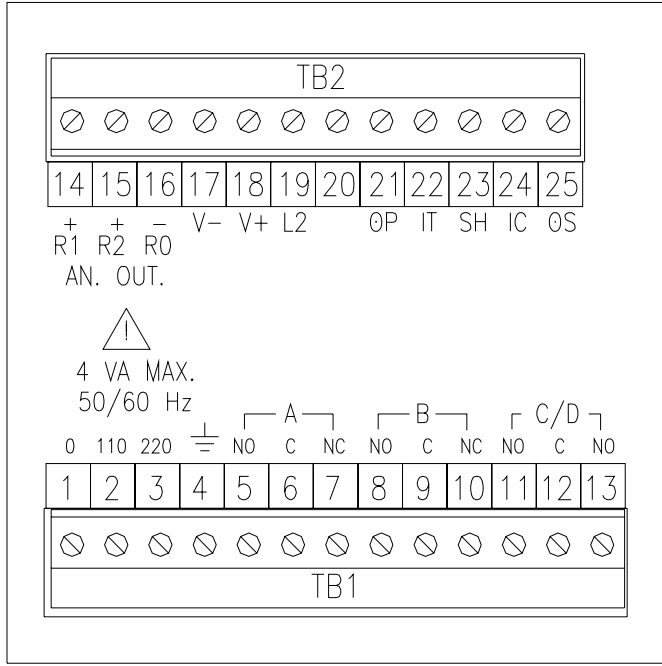

TB1

TB2

- | | |
|---|---|
| <ul style="list-style-type: none"> 1: AC POWER – Neutral 2: AC POWER – 110V – HOT 3: AC POWER – 220V – HOT 4: AC – GROUND (SOLUTION GND IF NECESSARY) – DRAIN WIRE 5: RELAY A – Normally open 6: RELAY A – Common 7: RELAY A – Normally closed 8: RELAY B – Normally open 9: RELAY B – Common 10: RELAY B – Normally closed 11: CLEANER RELAY C – Normally open 12: RELAY C/D – Common 13: CLEANER RELAY D – Normally open | <ul style="list-style-type: none"> 14: 4–20 mA OUTPUT CHANNEL 1 (+) 15: UNUSED 16: 4–20 mA OUTPUT CHANNEL (-) 17: SENSOR -12V – RED 18: SENSOR +12V – GREEN 19: SENSOR CONTROL LED – BLUE 20: UNUSED 21: SENSOR COMMON – BROWN 22: SENSOR HI TURBIDITY SIGNAL – YELLOW 23: SENSOR SHIELD – COPPER BRAID 24: SENSOR CHECK SIGNAL – WHITE 25: SENSOR LO TURBIDITY SIGNAL – GRAY |
|---|---|

SYSTEM WIRING DIAGRAM w/OPTIONAL JUNCTION BOX

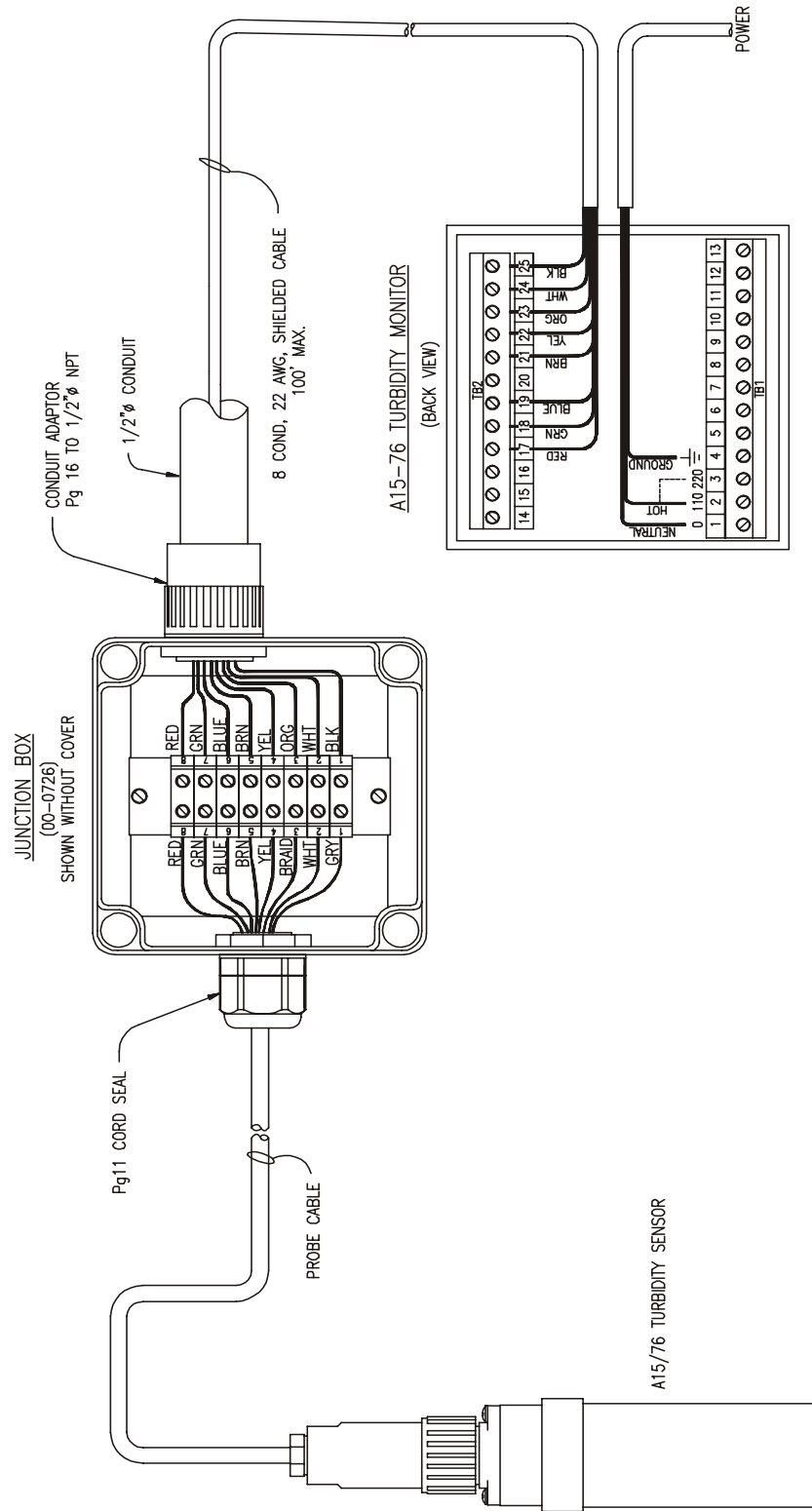

FLOW SENSOR DIMENSIONS

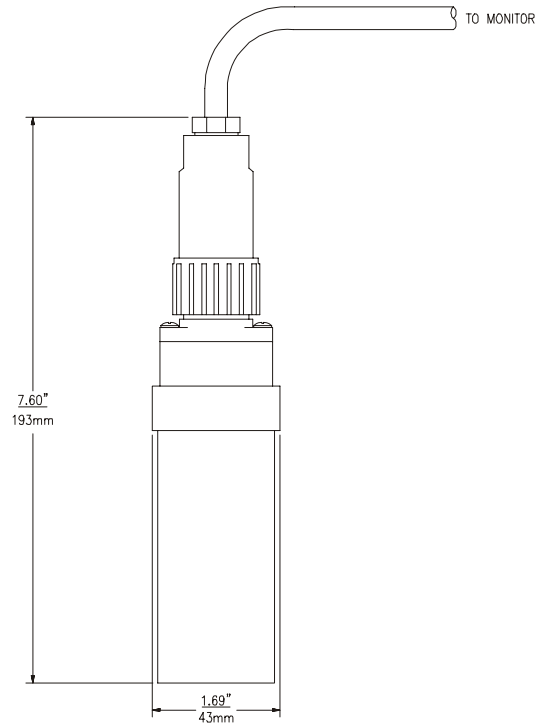

ATI-0434

FLOWCELL DIMENSIONS

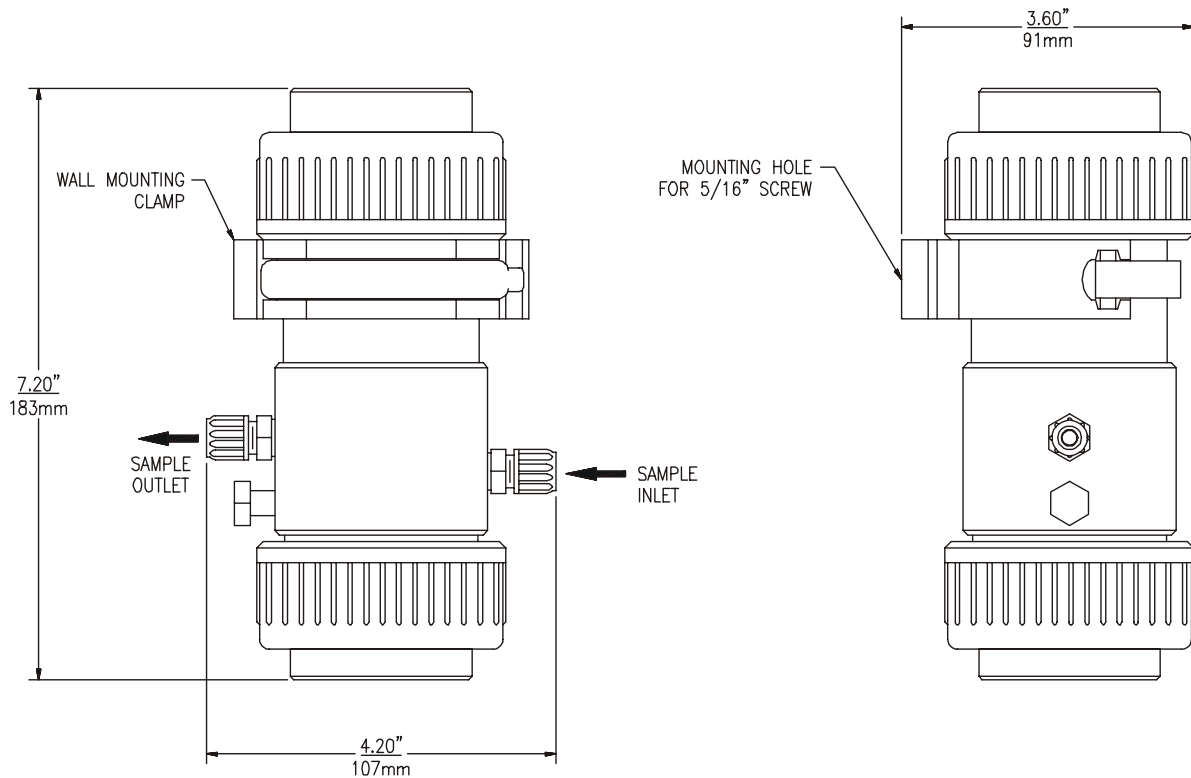

ATI-0435

FLWSENSOR/FLWCELL INSTALLATION DRAWING

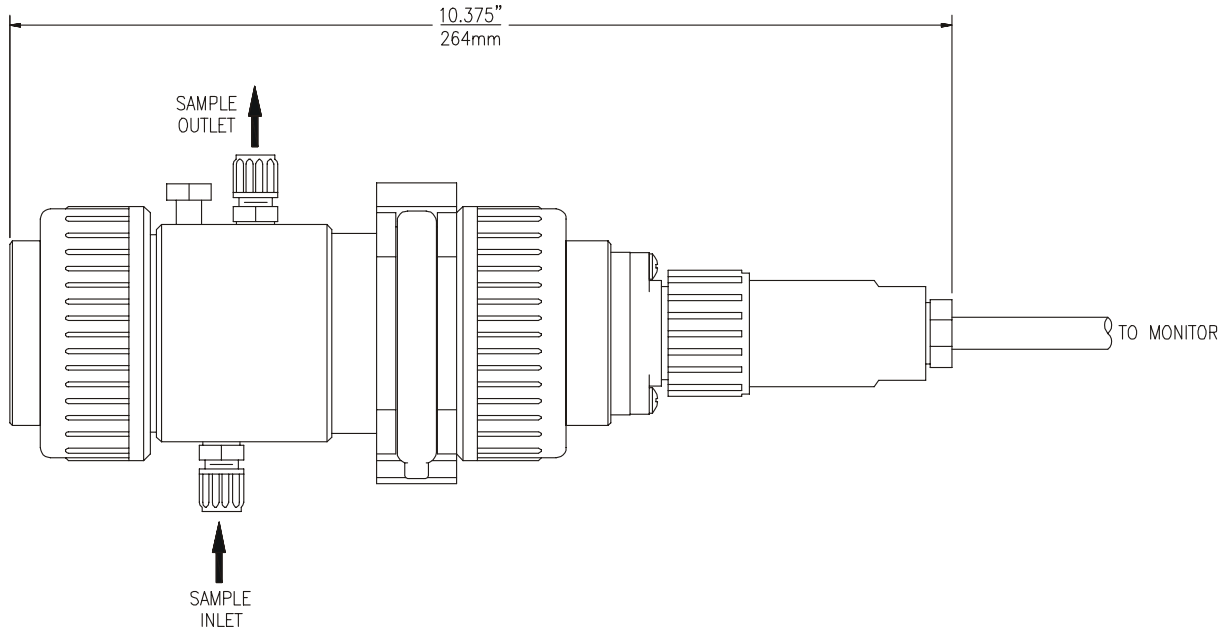

ATI-0444

Installation of flowcell must be done Horizontally as shown above.

TURBIDITY SENSOR 1½ FLOW TEE ASSEMBLY

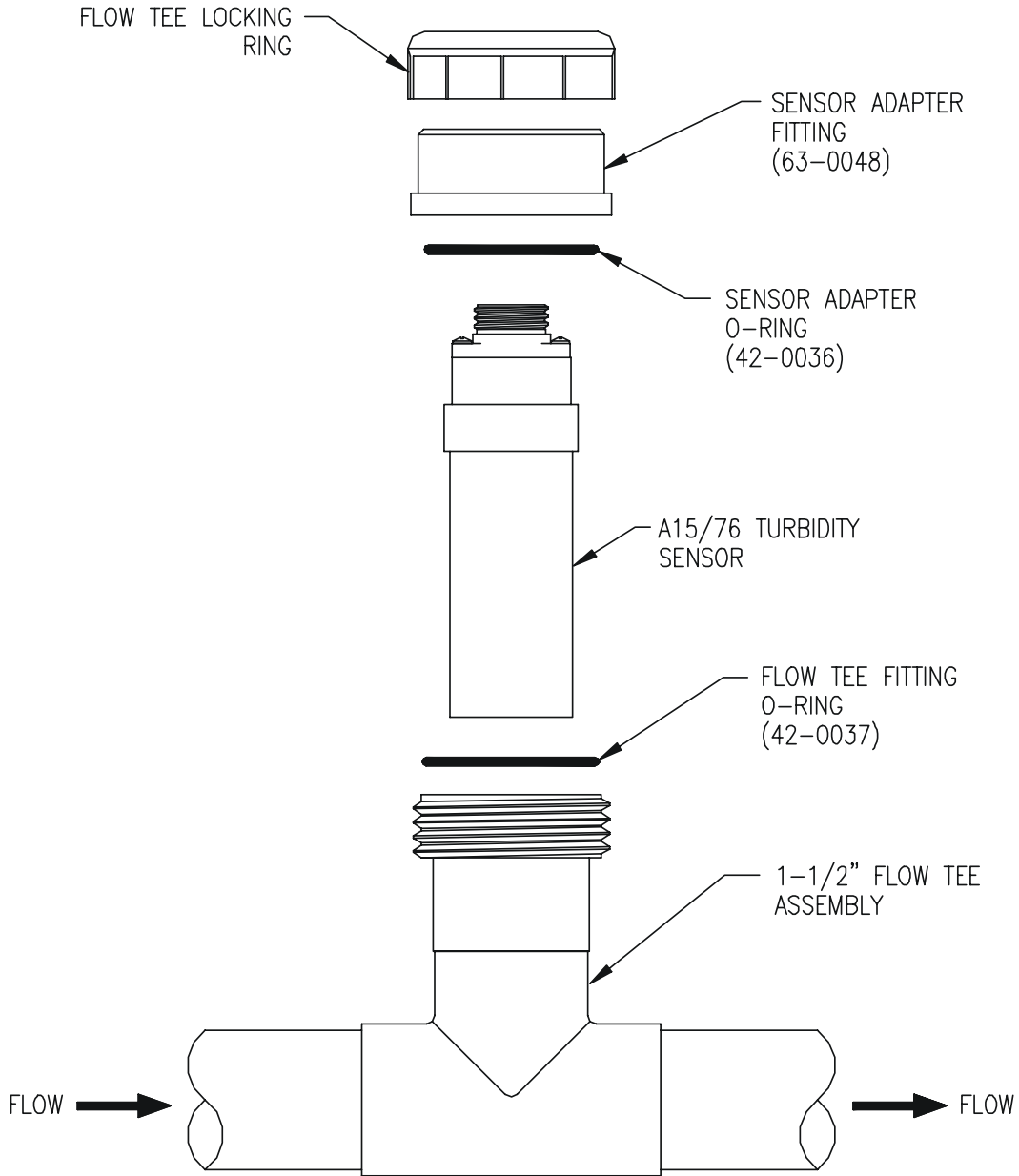

VERTICAL CONFIGURATION IS RECOMMENDED BUT HORIZONTAL CONFIGURATION IS ACCEPTABLE, PROVIDED SENSOR IS MOUNTED IN THE 3:00 OR 9:00 POSITION.

ATI-0542

FLOW "T" RECOMMENDED PIPING

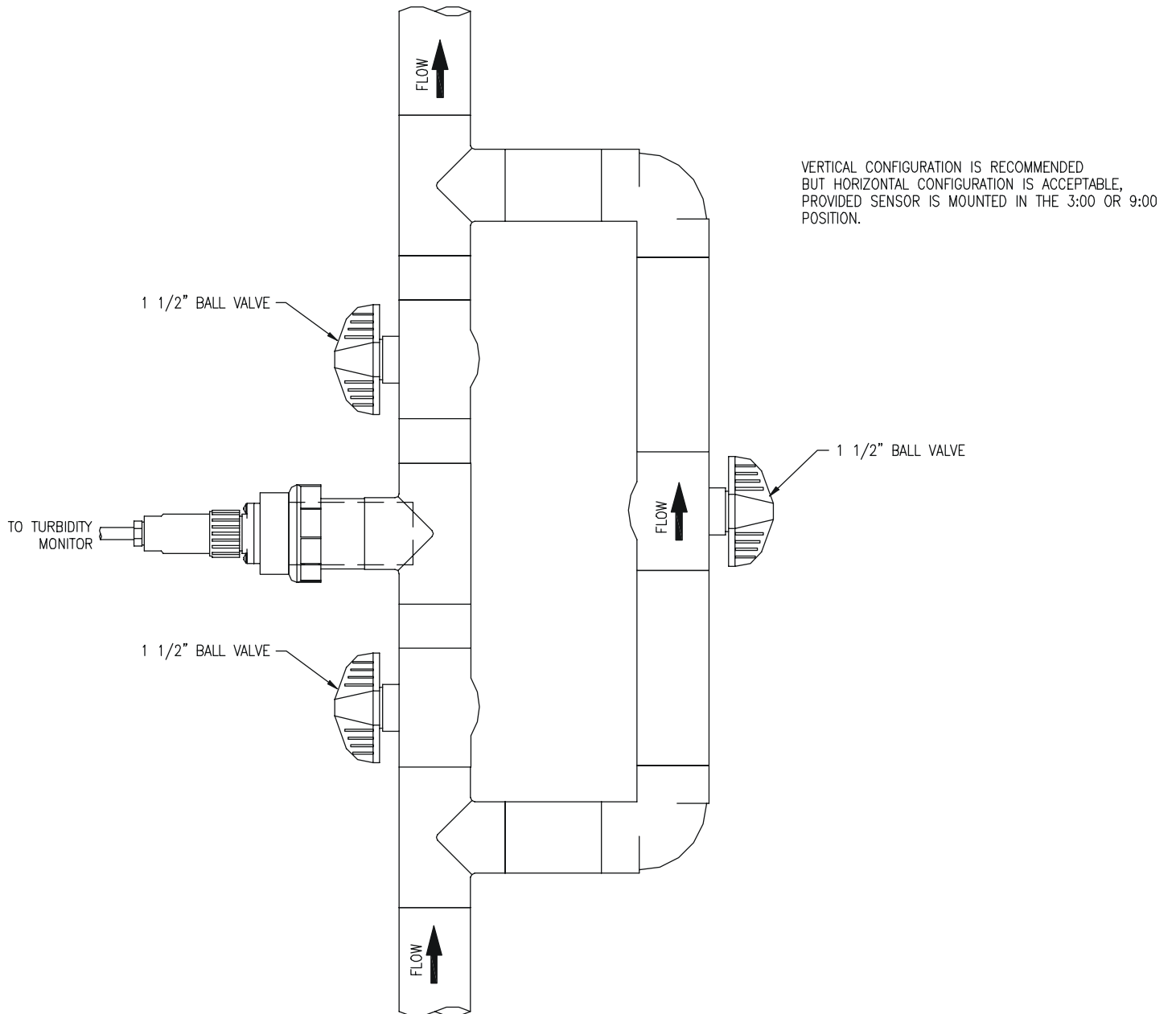

ATI-0513

D15/76 AUTO-CLEAN TURBIDITY MONITOR

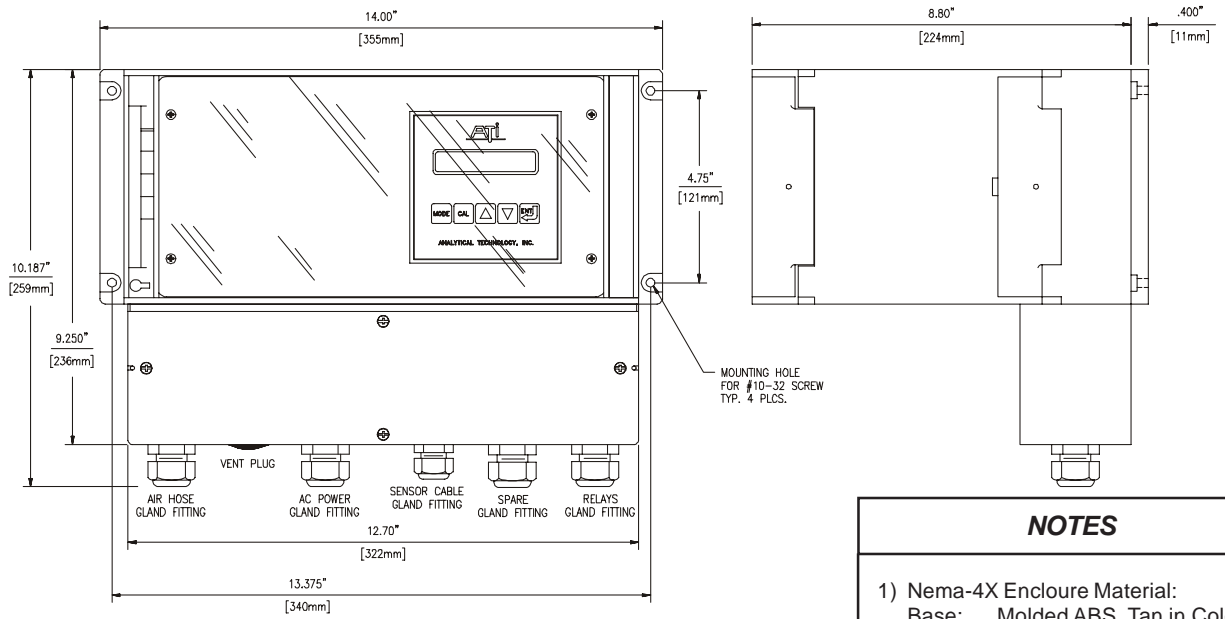

ATI-0473

NOTES

- 1) Nema-4X Enclosure Material:
Base: Molded ABS, Tan in Color
Cover: Clear Lexan w/Dual Hinge
- 2) Nema-4X Rating:
Nema rated types 4, 4X
IEC 529 rated IP66
- 3) Sensor Material:
Noryl EN265 & Stainless Steel

AUTO-CLEAN TURBIDITY SENSOR

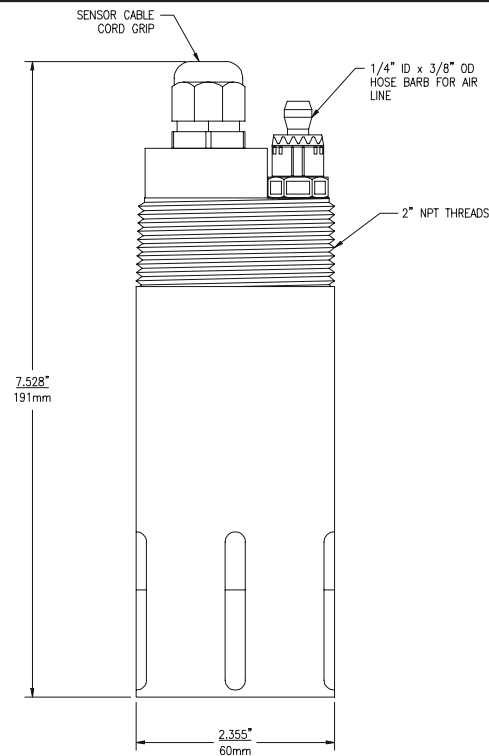

ATI-0553

MONITOR HANDRAIL INSTALLATION

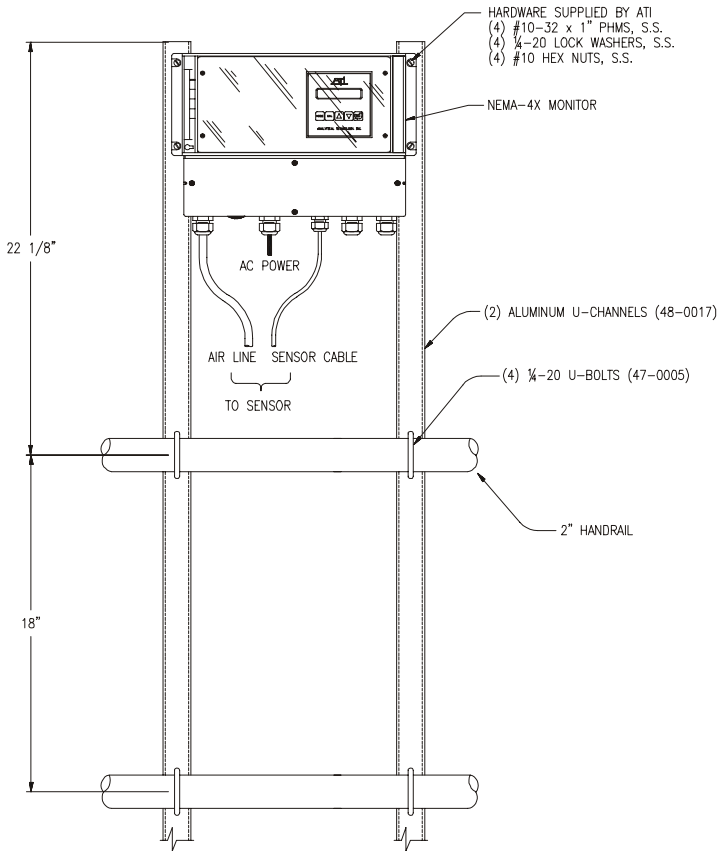

ATI-0490

NOTES

- 1) Always mount sensor cleaner within 25 ft. of sensor if possible. Maximum air line distance is 50 ft.
- 2) Sun shade over monitor is recommended in hot climates.
- 3) Monitor Handrail Mounting Kit # 00-0930 supplies all hardware listed for mounting monitor.
- 4) Wall mounting requires customer supplied screws or bolts.
- 5) Sensor Pipe Mounting Kit # 00-0624 supplies mounting plate with hardware and PVC pipe mounting adaptor.
- 6) Sensor Pipe Mounting Kit with Rag Shedder # 00-0629 supplies mounting plate with hardware and PVC rag shedder.

SENSOR HANDRAIL INSTALLATION

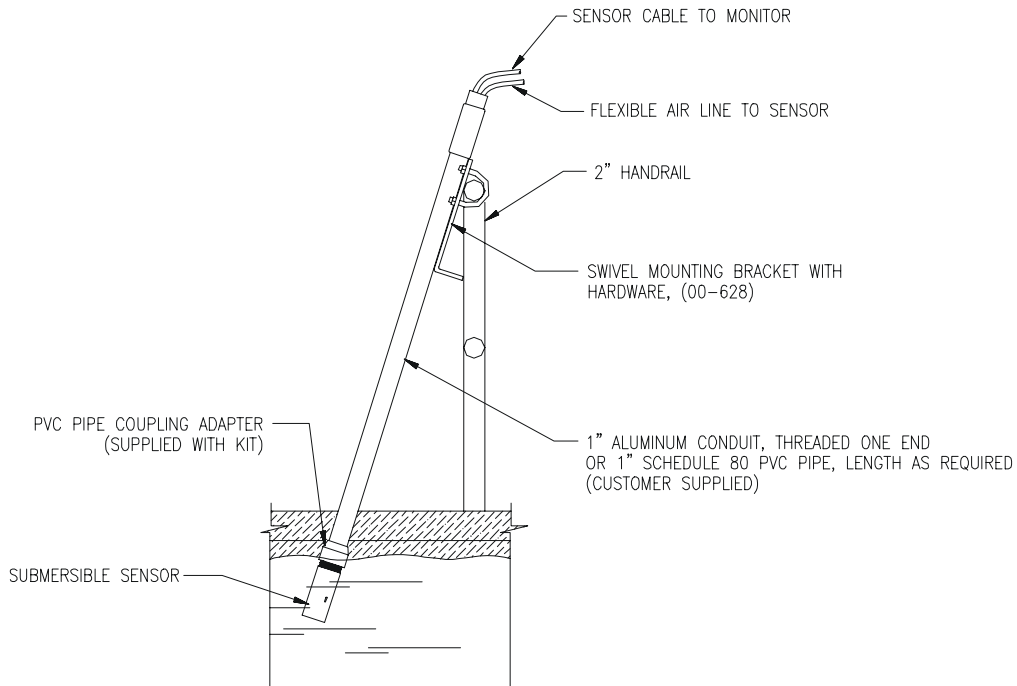

STANDARD SYSTEM WIRING DIAGRAM

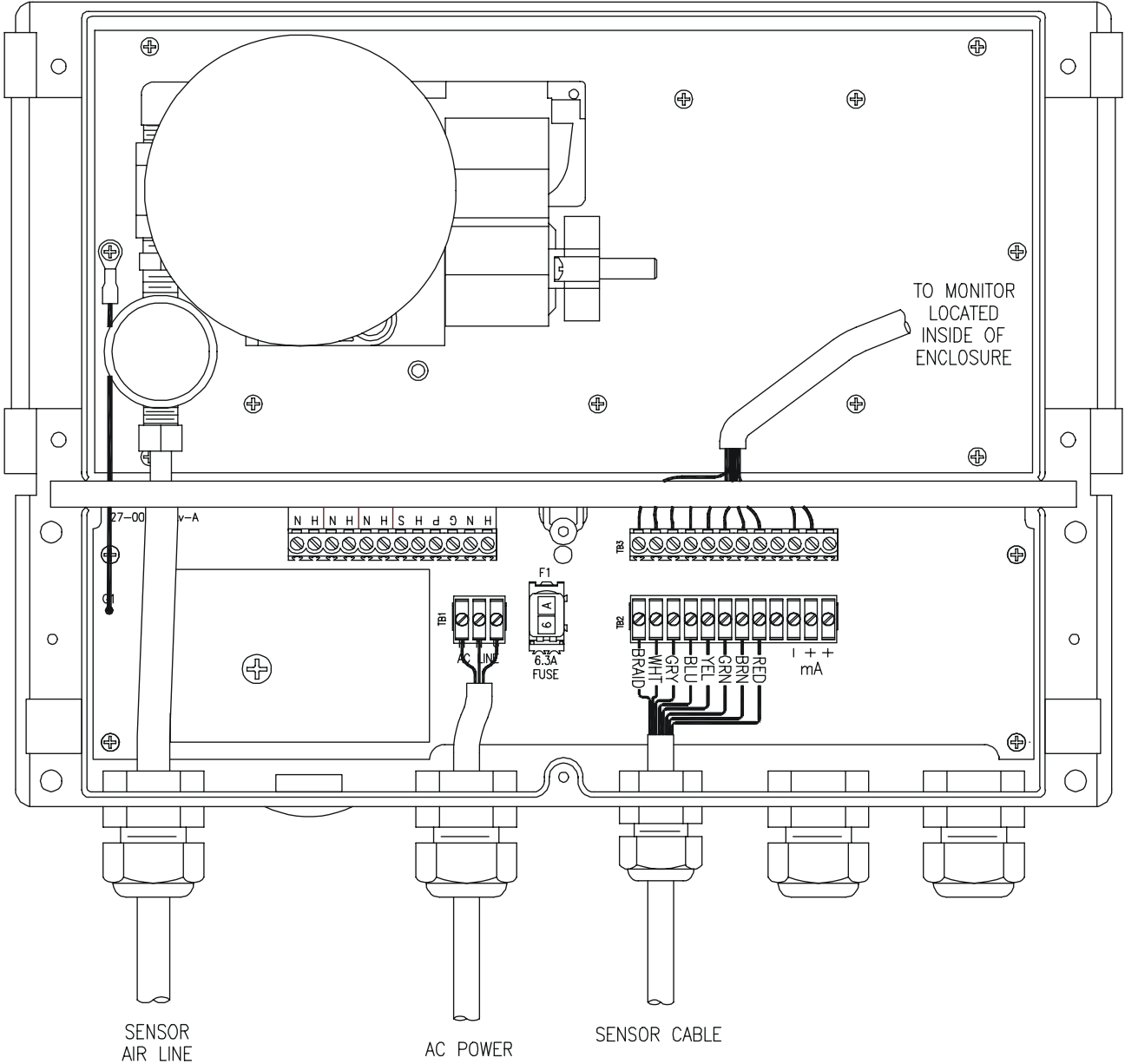

ATI-0534

